

how it works

To Broach or Not to Broach

Rotary broaching

Rotary broaching is a completely different process. It can cut the same forms as conventional broaching, but you can use it on your screw machine or lathe. A special rotary broaching tool holder mounts on the machine turret, and rotary broaching becomes just another step in your process. This eliminates the need for secondary operations to form square holes, hex holes, splines or gear teeth, or almost any other internal or external shape you want. Rotary broaching easily works in blind holes, which is not possible with conventional broaching.

A rotary broaching tool has cutting edges the shape of the hole or form you want. It mounts in a toolholder that holds the tool at a 1-degree axial tilt in relation to the center line of the workpiece. Bearings in the toolholder allow the tool to rotate freely. The workpiece is turning, and when the tool comes in contact, it rotates right along with the workpiece. Because of the 1-degree axial tilt, the tool appears to wobble as it rotates. Because of this, rotary broaching is sometimes called “wobble broaching.” It is also known as “Swiss broaching.”

Rotary broaching in action

Before the rotary broaching operation, the workpiece needs to be drilled or turned to the correct diameter for use with the rotary broaching tool. This minimizes the amount of material that the tool will cut. Then, the area where the tool will contact the workpiece is countersunk or chamfered, to allow smooth engagement of the tool. If the chamfer or countersink is not acceptable in the final part, you can design your process to remove it afterward. Then the part is ready for broaching. The following describes internal rotary broaching; external is similar.

As the prepared workpiece is turning,



Above: Internal and external rotary broaching tools, with sample parts.
Photo courtesy of Somma Tool Company, Inc.

the rotary broaching tool/toolholder advances toward it. Because of the 1-degree axial tilt, only one corner of the tool engages the workpiece at first. When the tool makes contact, the workpiece drives the tool to rotate in unison with it. During rotation, first one corner of the tool contacts the workpiece, then the next, and so on, around and around.

As the tool advances into the workpiece, each corner, in turn, cuts into the metal. This way, bit by bit, the tool cuts a shape that matches the shape of the tool.

How large a form you can rotary broach depends on the material. In aluminum, you

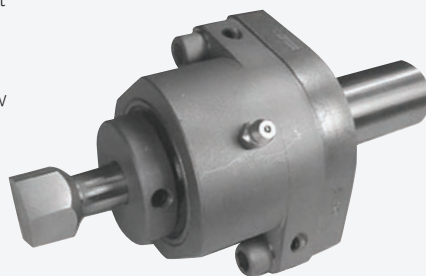

Above: Rotary broaching toolholder and broach.
Photo courtesy of Somma Tool Company, Inc.

can usually rotary broach up to 2", in steel to 1". You can rotary broach harder materials, but in smaller sizes. For example, you could broach a quarter-inch hole in Inconel, said Peter Bagwell, engineer at Slater Tools Inc., Clinton Township, Mich.

Toolholders and setup

The technology was developed decades ago, but rotary broaching companies continue to improve tool holders and tools to increase tool life and make the technique easier to use. Because of the precision alignment and offset required, rotary broaching tool holders traditionally required many adjustments and painstaking setup, which could take considerable time, depending on the employee's experience. A standard rotary broach setup might include six set screws, two bolts with nuts and a sliding plane between the toolholder body and the machine adapter.

Rotary broaching engineers have developed innovations to streamline setup procedures. A specially designed tapered-centering-pin gage can allow you to set up a fully adjustable tool holder in a minimum of time, said Dick Noti, sales engineer at Somma Tool Company, Inc., Waterbury, Conn. Some toolholders require only an X-axis adjustment, and, in recent years, no-adjustment rotary broaching toolholders for Swiss-type machines have become available.

If you are sending out parts for broaching, or have a job that might take advantage of rotary broaching, contact a rotary broaching tool manufacturer. An application engineer can look at the part and advise you. If you're not sure you want to make the investment, many suppliers will let you try out a toolholder and broaches on your own machine, without obligation.

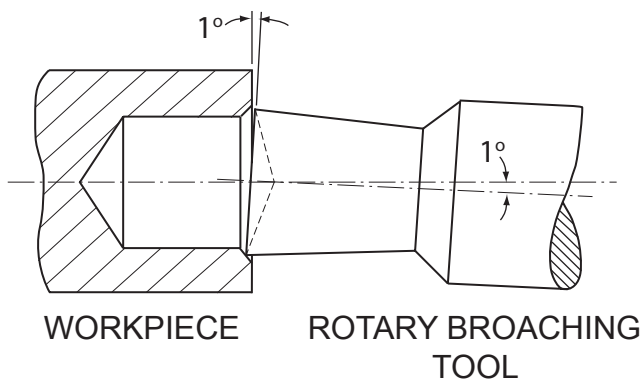

Above: How rotary broaching works.
Illustration provided by Barbara Donahoe & Somma Tool Company, Inc.

Cutting fluids also influence the tool life and part finish, of course. Generally, you should use a good water-soluble oil, Nemecc said. In more challenging applications a heavy cutting oil may be needed. Many cutting fluid suppliers offer specially formulated coolants for broaching applications. Your machine manufacturer and tool supplier can recommend appropriate coolants.

With brass parts you'll want to use a water-soluble oil that won't discolor the material. You'll also need a water-soluble fluid with certain thin-walled parts. "Especially for internal [broaching] with thin wall sections, sometimes coolant can make a difference in what your final tolerance is," said West. "If you broach a round hole [with] a thin wall, it gets hotter than blazes and expands." In this case, a water-soluble oil will help dissipate the heat.

Whether you broach high-volume parts yourself or send them out for broaching, you can take advantage of the capabilities of this time-honored process: precision, low per-part cost and the ability to cut complex forms with accuracy and repeatability not found with many machining processes.



Contributors to this article:

American Broach & Machine Co.: www.americanbroach.com

Slater Tools Inc.: www.slatertools.com

Somma Tool Company, Inc.: www.sommatool.com

V-W Broaching Service, Inc.: www.vwbroaching.com

July/August 2009

KNURLING PROBLEMS?

With the most knowledgeable engineers and sales staff, Accu Trak has the answers to any technical question regarding the knurling process.



We have available for immediate delivery a huge variety of knurling wheels and holders in **both** "INCH" and "METRIC" sizes as well as custom knurls made to your exact requirements with the fastest delivery in the industry.

For more info on how to ensure your next knurling job runs smoothly



visit us online at
www.accu-trak.com
or call
(800) 433-4933.



Precision Grinding



- BioDur® 316LS stainless
- BioDur® 108 alloy
- BioDur® TrimRite® stainless
- Custom 455® stainless
- Custom 465® stainless
- Titanium alloys
- Tolerances to .000050"
- Finishes to 3Ra



11 Presidential Way
Woburn, MA 01801
Phone: 781.994.5000
Fax: 781.994.5001
info@bostoncenterless.com

Straightness, roundness and size tolerance are essential to medical component manufacturing. At Boston Centerless, we understand your needs and provide materials precisely to specification each and every time, allowing your machining process to run smoothly. We have a state-of-the-art facility with an extensive inventory of medical alloys.

ISO 9001:2000 Certified

BioDur, Custom 465, Custom 455 and TrimRite are registered trademarks of CTS Holdings, Inc., a subsidiary of Carpenter Technology Corporation.

800-343-4111 • www.bostoncenterless.com